

Bevels Off Outer Face of Seat Outboard Carling											
Position	-3700	-3900	-4100	-4300	-4500	-4700	-4900	-5100	-5300	-5500	Aft End
Bevel	0	0	1	2.5	4	5	5	5	5	5	5

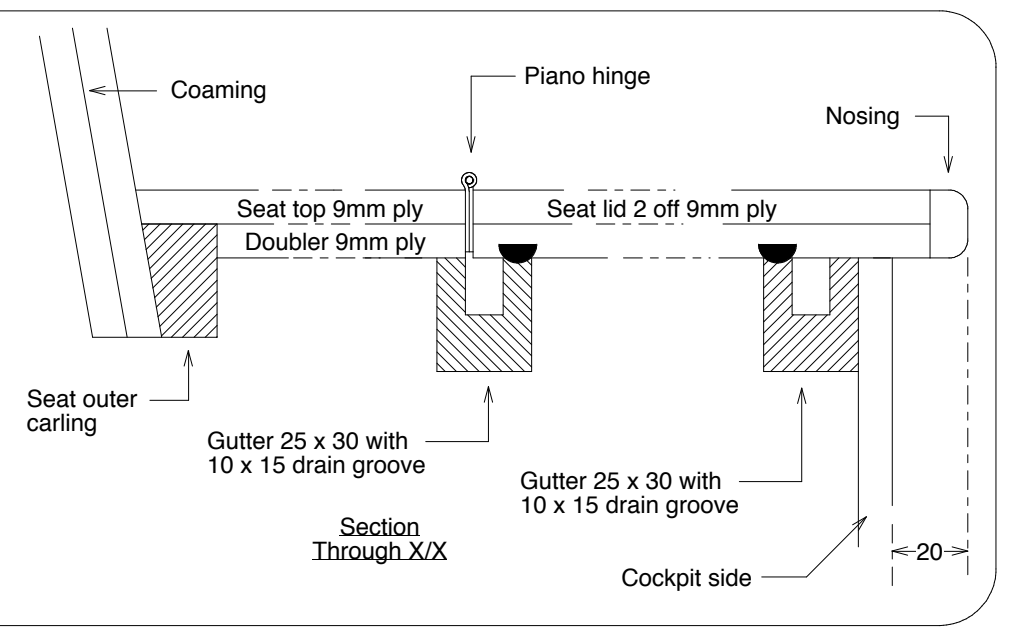
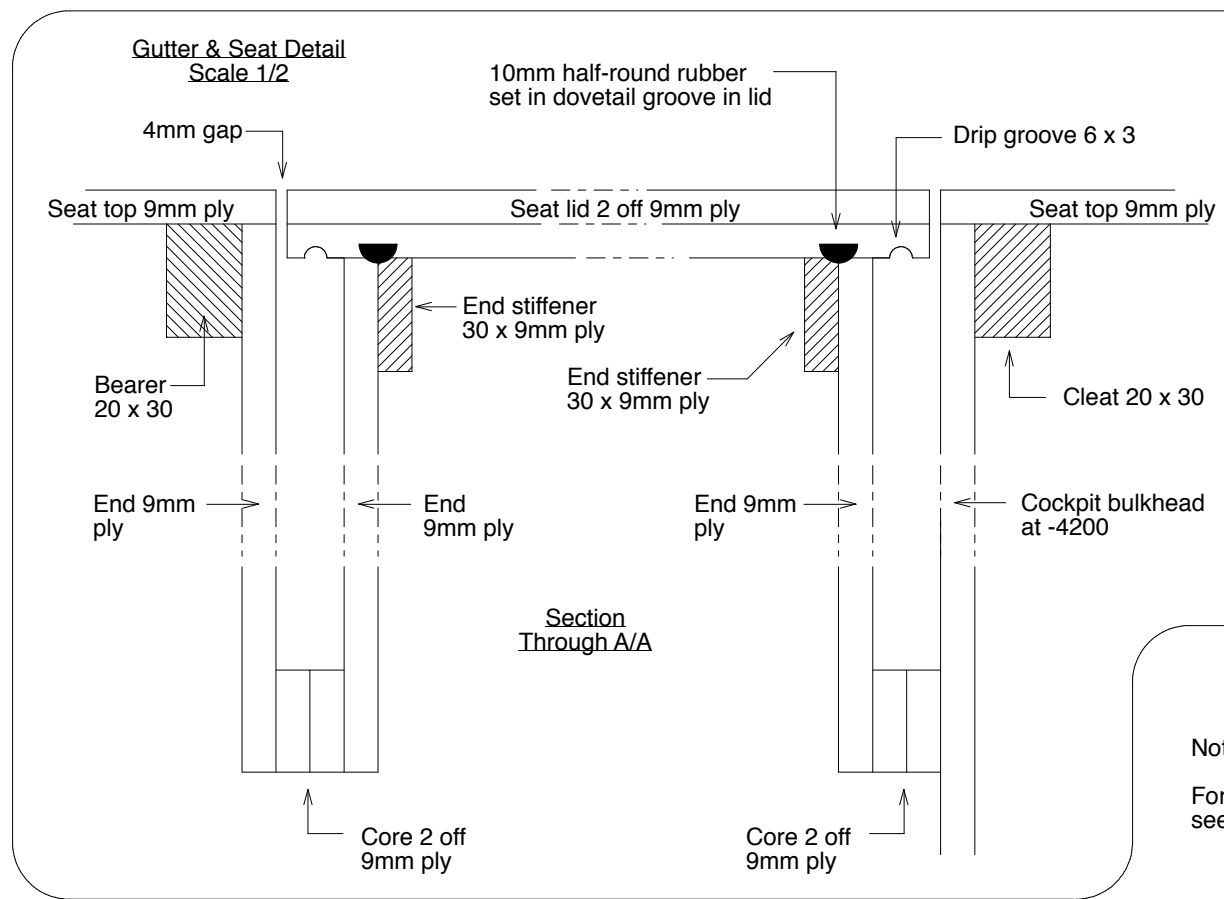
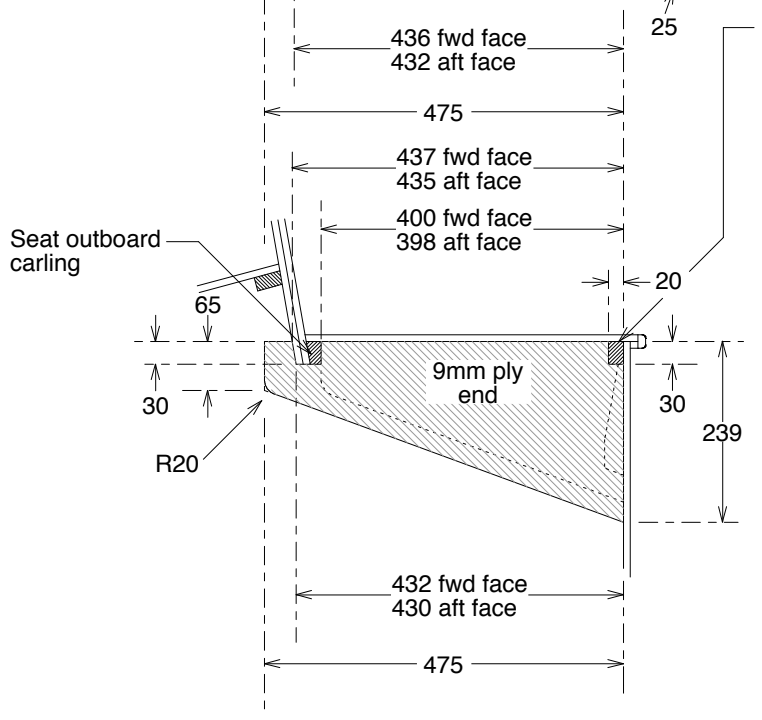

Aft Gutter Assembly

Section Through A/A

Section Through X/X

Note:  
For shape of seat top, lids and doubler see Drawing 165/009/008.

**Whisstock** boats and boat plans support@whisstock.com

**Design 165**  
**Port Cockpit Seat Structures**

Scale 1/10 & 1/2  
Date Jul 10 2014  
Plan No. 165/009/006  
Issue No. 01

All dimensions in millimetres unless otherwise noted

© Debenriver Ltd 2014. All Rights Reserved